

AS300 AURORA

Fixed High Temperature Detector

INSTALLATION AND MAINTENANCE INSTRUCTIONS

Figure 1
AUBDR100 Mounting Base
Wiring Connections

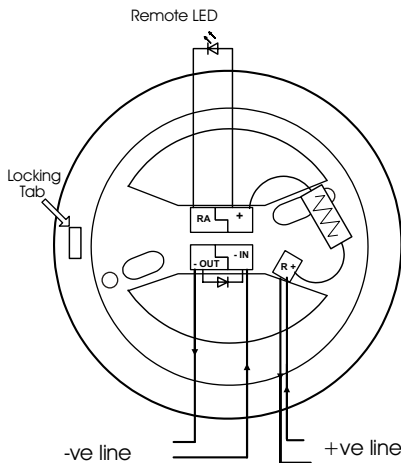

1. Product Specifications

Supply Voltage: 10-30Vdc
 Average Standby Current: Max 40uA @ 24V T= 25°C
 Alarm Current: Max 50mA
 Alarm current limited according to value of resistor in mounting base (Terminal R+ must be used as shown in Figure 1)
 External LED Current: Max 8mA
 Detector Height: 54mm with base
 Diameter: 110mm
 Weight: 130g with base
 Alarm smoke density: in accordance with EN54-5 Class BS limits
 Humidity: 95%RH non-condensing
 Operating temperature: -30 to +60°C (no icing)

2. Base Mounting and Wiring Instructions

Terminals connections are shown in Fig. 1. The positive in and out wires must be connected to the "R+" terminal whilst the negative wires must be connected to the "-" marked terminals. When using the AUBDR100 Universal Base it is critical that the negative in and out wires be split and connected to the terminals as shown in Figure 1 since otherwise line continuity may not be maintained if a detector is removed (as required by BS5839-1).

If it is known that sufficient current limiting is provided by the panel the positive wires may be connected to the terminal marked "+". Panel current limiting must not allow the alarm current to the detector to exceed 50mA. If the alarm current is allowed to exceed the maximum specified then the detector may be permanently damaged and will be excluded from warranty cover. If any doubt exists then use the R+ terminal.

Warning – Before making connections to mounting bases and installing detectors ensure that power has been removed from detector monitoring circuits. Confirm system compatibility with your supplier or the panel manufacturer.

3. Detector Installation

- Position the detector centrally on its mounting base and rotate clockwise applying gentle pressure. The detector will drop into its keyed location. Continue to rotate clockwise a few degrees until the detector has firmly engaged in the mounting base.
- After installing all detectors, apply power to the detector monitoring circuits.
- Test the detectors as described in the section below, headed "Testing."

Anti-Tamper Feature:

The small plastic tab on the side of the base can be removed by inserting a lid probe through the access hole on the side of the mounting base. A tool must then be used to release the locking tab, which will allow the detector to be removed from its base.

Warning – During commissioning (assuming all building activities in the area have been completed) ensure the protective dust cover has been removed from each detector.

4. Testing

Detectors should be tested during system commissioning and when required during scheduled periodical maintenance. When the system has been reset after each test allow at least one minute for power stabilization before carrying out the next test.

Heat Testing

- Use a heat test tool from an approved manufacturer in accordance with their application instructions. This is important to prevent possible damage to the detectors.
- The red LED alarm indicator on the detector should illuminate (normally within 30 seconds but this may vary according to test conditions and procedures) and an alarm condition should be activated at the control panel.

Magnet Testing

- Position the test magnet level with the smoke entry ports

approximately 100° anti-clockwise from the locking tab access hole on the side of the mounting base.

- The red LED alarm indicator on the detector should illuminate within 30 seconds and an alarm condition should be activated at the control panel.

Detectors which do not operate as described above require attention as detailed under "Maintenance", after which a new test should be carried out.

5. Maintenance

Before starting any maintenance work, isolate and disable the system, to avoid accidental unwanted alarm conditions. Remove the detector from its mounting base to allow inspection at ground level in good light. Inspect the smoke entry ports around the detector and use a small, soft bristle brush to dislodge any obvious contaminants such as insects, spider webs, hairs, etc. Use a small vacuum tube or clean, dry compressed air to pull or blow any remaining small particles away from the smoke entry screen area. Wipe the exterior housing of the detector with a clean, damp, lint free cloth to remove any surface film that can later attract air-borne contaminants. Replace the detector in its mounting base and check correct operation as described under "Testing" after all detectors have been inspected and power has been re-applied.

6. System operation

Each detector mounting base has two "-" marked terminals. These are electrically identical, but they are connected to each other only when a detector is correctly fitted onto the base. The Schottky diode fitted in the AUBDR100 mounting base provides continuity to the next detectors or callpoints if one detector is temporarily removed. This feature is used in combination with an appropriate End of Line (EOL) component designated by the panel manufacturer to indicate a fault condition if a detector is removed from its base. To enable the function to operate correctly it is important that incoming and outgoing negative wires are separated. A typical installation scheme is shown in Fig. 2.

Warning & Limitations

Our detectors use high quality electronic components and plastic materials that are highly resistant to environmental deterioration. However, after 10 years continuous operation it is advisable to replace detectors to reduce the risk of reduced performance caused by external factors. Ensure that these detectors are only used with compatible control panels. Detection systems must be checked, serviced and maintained on a regular basis to confirm correct operation.

Temperature detectors are set to respond at different thresholds dependent upon their classification, thus application advice should be sought concerning suitability and for special risks. Detectors cannot respond correctly if barriers exist between them and the fire location and may be affected by special environmental conditions. Refer to and follow National Codes of Practice and other internationally recognised fire engineering standards. Appropriate Risk Assessment should be carried out initially to determine correct design criteria and updated periodically.

Warranty

All detectors are supplied with the benefit of a limited 3 Year Warranty relating to faulty materials or manufacturing defects effective from the production date indicated on each product. This warranty is invalidated by mechanical or electrical damage caused in the field by incorrect handling or usage. Product must be returned via your authorised supplier for repair or replacement together with full information on any problem identified.

Full details on our Warranty & Products Returns Policy can be obtained upon request.



Figure 2
System Installation

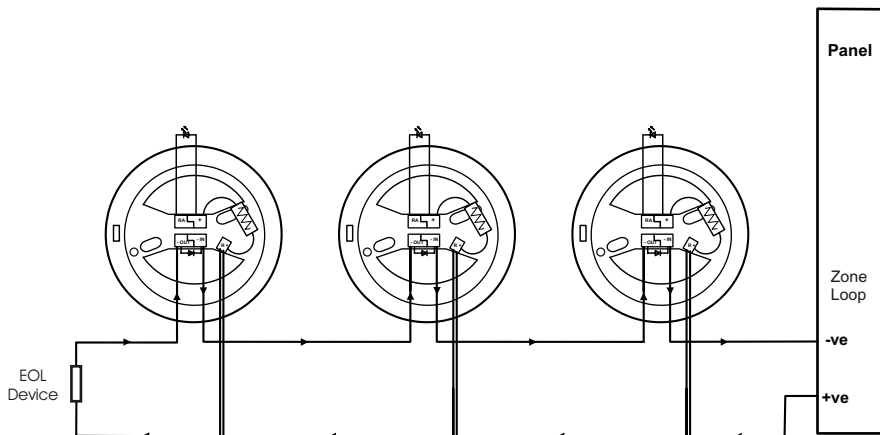

Supplied by:

Noby UK

Unit 1F Mill Fold
 Elland Road
 Ripponden
 HALIFAX
 West Yorkshire
 Hx6 4DJ